

## Fotel HELIX

Klasa 1/2 InterCity

## HELIX Seat

Class 1/2 InterCity



Typ taboru: wagony bezprzedziałowe

Szerokość oparcia: 450 mm

Szerokość siedziska: 450/500 mm

Type of car: open coach

Backrest width: 450 mm

Seat width: 450/500 mm

Konfiguracja: Fotel 1os., 2os.

Seat types: Single seat, double seat

Wymiary zewnętrzne: 1108/1255/660 mm  
szer./wys./gł  
(fotel 2os.  
z podłokietnikami i kantilą)

External dimensions: 1108/1255/660 mm  
width/height/depth  
(double seat with armrests  
and cantilever)

Masa od: 44 kg  
(fotel 2os. bez podłokietników,  
siatki i kantili)

Weight from: 44 kg  
(double seat without armrests,  
magazine net and cantilever)

Rysunki poglądowe (I kl.):

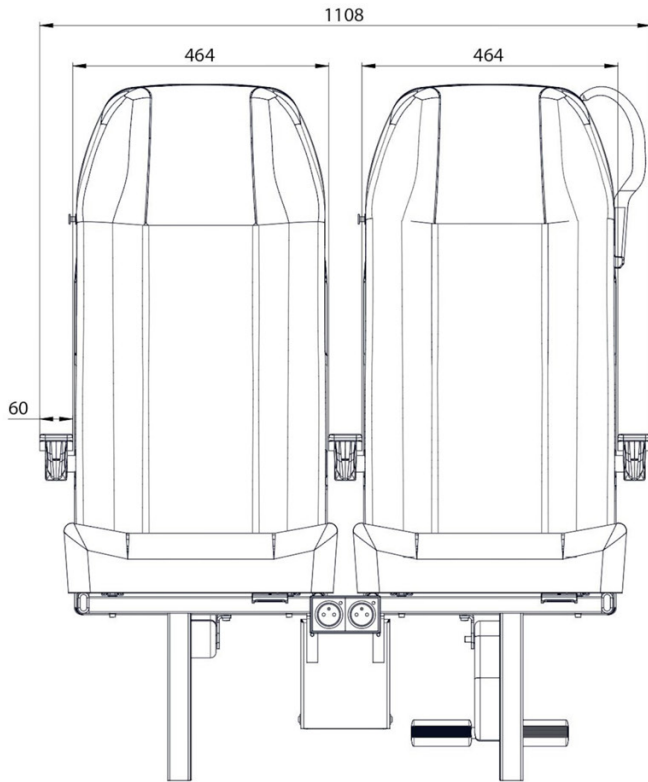

Dimensional drawings (Class I):

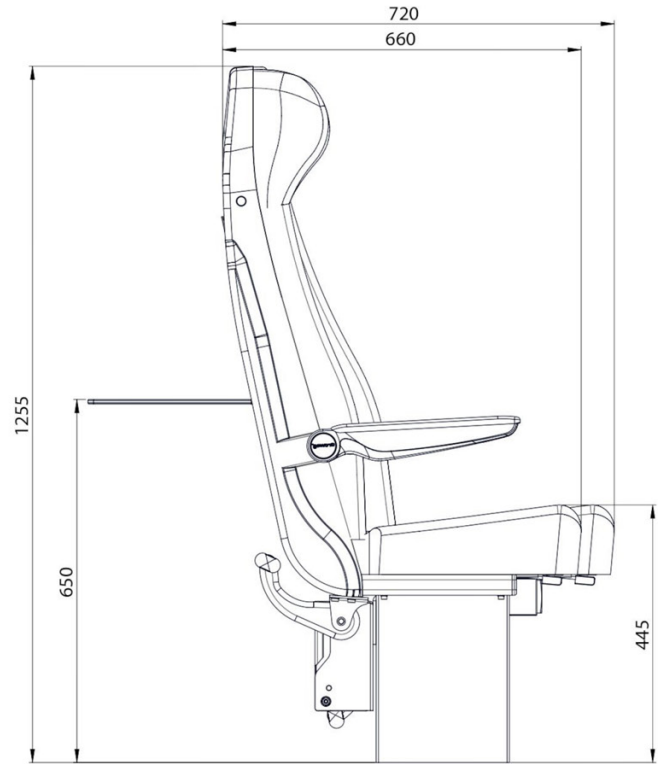

<b>Opcje:</b>	<ul style="list-style-type: none"><li>Ruchome podłokietniki</li><li>Numeracja miejsc</li><li>Numeracja w języku Braille'a</li><li>Uchwyt do trzymania</li><li>Regulowany podnózek</li><li>Składany stolik</li><li>Siatka na czasopisma</li><li>Śmietniczka</li><li>Wieszak stały</li><li>Wieszak chowany</li><li>Gniazdko elektryczne/port USB</li><li>Kinematyka siedziska i oparcia</li><li>Różne typy mocowań</li><li>Tapicerka wandaloodporna</li></ul>	<b>Accessories:</b>	<ul style="list-style-type: none"><li>Foldable armrests</li><li>Seat's numeration</li><li>Seat's numeration with Braille</li><li>Grip</li><li>Adjustable footrest</li><li>Foldable table</li><li>Magazine net</li><li>Waste bin</li><li>Coat hook</li><li>Retractable coat hook</li><li>Electric socket/USB port</li><li>Seat and back kinematics</li><li>Different fixation types</li><li>Antivandal upholstery</li></ul>
---------------	---	---------------------	--

Posiadamy normy: ISO 9001:2015  
EN 15085-2:2021 CL1  
DIN 6701

We meet following standards: ISO 9001:2015  
EN 15085-2:2021 CL1  
DIN 6701

**RECARO Rail Sp. z o.o.**  
62-065 Grodzisk Wlkp.  
Zdrój 49A, Poland

Telephone: +48 61 44 27 200  
Email: [info@recaro-rail.com](mailto:info@recaro-rail.com)  
Internet: [www.recaro-rail.com](http://www.recaro-rail.com)

NIP: 788-00-08-315  
Regon: 000030024  
KRS: 0000298838